



# **POWERLINE *XP I***

Swimming Pool Pump (Black color model)

3 FT CORD

UL/NEC Models 0-3295-206, 0-3296-206, 0-3297-206, 0-3298-206

25 FT CORD w/GFCI

UL Models 0-3295-200, 0-3296-200, 0-3297-200, 0-3298-200

6 FT CORD Models 0-3295-203, 0-3296-203, 0-3297-203,  
0-3298-203

---

---

**Owner's Guide**

---

---

# IMPORTANT SAFETY INSTRUCTIONS

## FOR ALL MODELS:

When installing and using this electrical equipment, basic safety precautions should always be followed, including the following:

1. **READ AND FOLLOW ALL INSTRUCTIONS.**
2. **WARNING** — To reduce the risk of injury, do not permit children to use this product unless they are closely supervised at all times.
3. **WARNING** — Risk of electric shock. Connect only to a grounding type receptacle protected by a Ground Fault Circuit Interrupter (GFCI). Contact a qualified electrician if you cannot verify that the receptacle is protected by a GFCI.  
(For storable pool pumps) This product is provided with a ground-fault circuit interrupter. If replacement of the plug or cord is needed, use only identical replacement parts.  
(For all permanently installed units) Connect only to a branch circuit protected by a ground-fault circuit-interrupter (GFCI)
4. Do not bury cord. Locate cord to minimize abuse from lawn mowers, hedge trimmers, and other equipment.
5. **WARNING** — To reduce the risk of electric shock, replace damaged cord immediately.
6. **WARNING** — To reduce the risk of electric shock, do not use extension cord to connect unit to electric supply; provide a properly located outlet.

**FOR UL MODELS ONLY:**  
**0-3295-200, 0-3296-200, 0-3297-200, 0-3298-200**

7. **CAUTION** — This pump is for use with storable pools only. Do not use with permanently installed pools. A storable pool is constructed so that it may be readily disassembled for storage

and reassembled to its original integrity. A permanently installed pool is constructed in or on the ground or in a building such that it cannot be readily disassembled for storage.

(For storable pools) The unit is provided with a ground-fault circuit-interrupter (GFCI). To test the GFCI, push the test button. The GFCI should interrupt power. Push the reset button. Power should be restored. If the GFCI fails to operate in this manner, the GFCI is defective. If the GFCI interrupts power to the pump without the test button being pushed, a ground current is flowing, indicating the possibility of an electric shock. Do not use this pump. Disconnect the pump and have the problem corrected by a qualified service representative before using.

**FOR UL/NEC MODELS ONLY:**  
**0-3295-206, 0-3296-206, 0-3297-206, 0-3298-206**

8. **CAUTION** — This pump is for use with permanently installed pools and may also be used with hot tubs and spas if so marked. Do not use with storable pools. A permanently installed pool is constructed in or on the ground or in a building such that it cannot be readily disassembled for storage. A storable pool is constructed so that it may be readily disassembled for storage and reassembled to its original integrity.

**FOR ALL MODELS:**

9. **SAVE THESE INSTRUCTIONS.**

## ELECTRICAL FEATURES

**FOR UL MODELS ONLY:**  
**0-3295-200, 0-3296-200, 0-3297-200, 0-3298-200**

Your pump is supplied with a 25-foot, 3-wire electrical cord and 3-pronged plug. The pump is double insulated and grounded. The pump electrical cord must be connected to a grounded, 3-wire, 115 VAC electrical receptacle. The receptacle must be protected by a Ground Fault Circuit

Interrupter (GFCI) in accordance with Article 680-31 of the National Electrical Code (NEC), (Section 68-204 of the Canadian Electrical Code [CSA]) and local codes or ordinances. For runs greater than 25 feet, consult your local licensed electrical contractor.

**FOR UL/NEC MODELS ONLY:**  
**0-3295-206, 0-3296-206, 0-3297-206, 0-3298-206**

Your pump is supplied with a 3-foot, 3-wire electrical cord and 3-prong flanged, twist-lock plug.

The pump electrical cord must be connected to a single twist lock, grounding type receptacle that is located a minimum of 6 feet from the inside pool wall.

A qualified electrical contractor must install this receptacle in accordance with Article 680-6 of the National Electrical Code (NEC). A Ground Fault Circuit Interrupter (GFCI) must be used. An ON/OFF switch must be installed at the receptacle.

**Use a Hubbell No. 2310 Receptacle, 20 AMP 125 Volt A.C. or an equivalent receptacle that meets NEMA Configuration L5-20R.**

This pump is double insulated and grounded. Dead metal parts are not in contact with pool water.

**FOR 6FT cord MODELS ONLY:**

Your pump is supplied with a 6-foot, 3-wire electrical cord and 3-pronged plug. The pump is double insulated and grounded. The pump electrical cord must be connected to a grounded, 3-wire, 115 VAC electrical receptacle. **The receptacle must be protected by a Ground Fault Circuit Interrupter (GFCI) in accordance with Article 680-31 of the National Electrical Code (NEC), (Section 68-204 of the Canadian Electrical Code [CSA]) and local codes or ordinances.** For runs greater than 6 feet, consult your local licensed electrical contractor.

## IMPORTANT: INSTRUCTIONS AND SAFETY INFORMATION

If you have purchased a filtration system, follow the instructions provided with your filter instructing you to prepare the filter and pump foundation using patio blocks and a level.

Failure to use a pump base will cause the motor to overheat and will void any warranty.

Install filter and pump a minimum of 6 feet from the pool wall so they may not be used as steps by children.

### PUMP ASSEMBLY

1. Align the rectangle peg on the base with the mating hole in the pump housing (see pic below) and refer to exploded view. Turn the pump upside down and place the pump base into the notches in the pump. Attach the pump to the pump base using the four (4) 5/8" hex head screws supplied.



2. Place the O-rings over the threads of the hose adaptors and screw them into the intake and discharge ports on the pump.  
**Caution: Do not over-tighten.**

### INITIAL START-UP

1. If you have a Doughboy filtration system, follow the "Initial Start-Up" instructions in the filter owner's guide.

2. If this pump has been purchased as a replacement (and you are not referring to the filter instructions), the pump will have to be primed after all hose connections have been made and pool has been filled to the proper level. To prime the pump, loosen the pump strainer pot lid to allow air to escape. Tighten lid when water begins to flow between strainer pot body and lid. Do not overtighten.

### CLEANING STRAINER BASKET

1. Stop pump. Insert a winterizing disk, or stuff a rag into the return fitting to close off water flow from the pool.
2. Remove skimmer basket. Stuff a rag into the bottom of the skimmer outlet port.
3. Remove strainer pot lid, lift out basket, and clean thoroughly. When replacing the basket, align notch in basket with rib in strainer pot. Clean and lubricate O-ring with a non-petroleum lubricant. Consult your pool store for proper lubricant. Replace lid. Remove winterizing disk and/or rags, and replace basket and skimmer lid. Only hand-tighten the lid.

### MAINTENANCE

**Make sure the pump is disconnected from the electrical source before attempting any maintenance work.**

#### LUBRICATION:

Periodically lubricate the O-ring under the strainer cover with a non-petroleum lubricant recommended for A.B.S., Noryl and Acrylic plastics. Consult your pool dealer for lubricant selections.

If you have questions or require assistance, contact your local pool dealer.

## TROUBLE SHOOTING CHECKLIST

**NOTE: ALWAYS BE SURE PUMP IS DISCONNECTED FROM ELECTRICAL SOURCE BEFORE ATTEMPTING ANY MAINTENANCE OR REPAIR WORK.**

<b><u>PROBLEMS:</u></b>	<b><u>POSSIBLE CAUSE:</u></b>	<b><u>REMEDIES:</u></b>
1. Motor will not start.	<ol style="list-style-type: none"> <li>1. Pump not plugged in.</li> <li>2. Faulty electrical outlet.</li> <li>3. Low voltage.</li> </ol>	<ol style="list-style-type: none"> <li>1. Make sure pump is plugged into a grounded, 3-wire, 115 V. electrical receptacle that is not overloaded with other appliances.</li> <li>2. Check for improper or loose connections, open switches or relays, blown circuit breaker or fuses.</li> <li>3. The use of an electrical extension cord may cause a low power source. Have a qualified electrician install a Ground Fault Circuit Interrupter (GFCI) for direct electrical access.</li> </ol>
2. Pump will not prime.	<ol style="list-style-type: none"> <li>1. Air in pump.</li> <li>2. Clogged inlet and/or outlet connections.</li> </ol>	<ol style="list-style-type: none"> <li>1. Make sure pool is filled to proper level. Make sure pump, strainer pot and hoses leading to and from pump are filled with water. Make sure strainer cover is secure and cover O-ring is clean and properly sealed. Keep hose connections tight to prevent water and/or air leaks.</li> <li>2. Clean out strainer basket, skimmer basket and hoses if necessary.</li> </ol>
3. Motor will stop without being turned off, then restart later.	<ol style="list-style-type: none"> <li>1. A too long or too light extension cord.</li> <li>2. Blocked air vents on bottom of pump housing causing motor to overheat.</li> <li>3. There may be a bind in motor causing overload.</li> <li>4. Thermal protector in motor is faulty.</li> </ol>	<ol style="list-style-type: none"> <li>1. Have a qualified electrician install a Ground Fault Circuit Interrupter (GFCI) for direct electrical access, or use a heavier gauge extension cord.</li> <li>2. Properly elevate pump 2 to 3 inches above foundation according to instructions.</li> <li>3. Locate bind and remove cause.</li> <li>4. Replace motor.</li> </ol>
4. High pressure gauge reading with low return flow.	<ol style="list-style-type: none"> <li>1. Filter is dirty.</li> <li>2. Plugged or restricted return line.</li> </ol>	<ol style="list-style-type: none"> <li>1. Backwash Filter.</li> <li>2. Plug skimmer and return fitting, then clear debris from return line.</li> </ol>
5. Low pressure gauge reading with low return flow.	<ol style="list-style-type: none"> <li>1. Plugged or restricted impeller.</li> <li>2. Clogged skimmer basket and/or plugged suction line leading to pump.</li> </ol>	<ol style="list-style-type: none"> <li>1. Plug skimmer and return fitting, then disassemble pump and clean impeller.</li> <li>2. Plug skimmer and return fitting, then clear debris from suction line.</li> </ol>
6. Leak from front of pump.	<ol style="list-style-type: none"> <li>1. Defective pump O-ring.</li> <li>2. Worn pump seal set.</li> <li>3. Cracked pump volute.</li> </ol>	<ol style="list-style-type: none"> <li>1. Replace pump O-ring.</li> <li>2. Replace pump seal set.</li> <li>3. Replace pump volute.</li> </ol>

## PUMP & MOTOR PARTS LIST

ITEM	P/N	QTY	DESCRIPTION	MODEL
1	1121-1429	1	Strainer Cover	All
2	308-1065	1	Strainer O-Ring	All
3	1107-1018	1	Strainer Basket	All
4	1121-2008	1	1/4" Pipe Plug w/O-ring(not shown)	All
5	321-1021	6	1/4" -20 Flange Nut	All
6	340-2288	1	Strainer Pot	All
7	308-1064	1	Pump O-Ring	All
8	340-2682	1	Pump Volute	All
9	1107-1388	1	Impeller	3/4 - 1 HP Models
	1107-1547	1	Impeller	1-1/2 - 2 HP Models
10	1121-1057	1	Seal Set	All
11	1107-1659	1	Pump Housing	All
12	330-1106	6	1/4"-20 x 2" Flange Bolt	All
13	300-1028	1	3/4 HP Motor 60 HZ	0-3295-xxx
	300-1028	1	1HP Motor 60 HZ	0-3296-xxx
	300-1102	1	1-1/2 HP Motor 60 HZ	0-3297-xxx
	300-1109	1	2 HP Motor 60 HZ	0-3298-xxx
13a	310-1054	1	Baffle foam (not shown)	All
14	1121-1967	1	Motor Enclosure	All
14a	340-2608	1	Strainer cover wrench (not shown)	All
15	330-1023	4	8 x 5/8" Hex Washer Screw	All
16	343-1074	1	Switch Hole Plug	Not required
17	1100-1707	1	Power Cord - 6'	-203 models
	1100-1115	1	Power Cord - NEC/UL - 3'	-206 models
	—	—	—	—
	1100-1695	1	Power Cord 25' GFCI 3/4&1HP	0-3295-200, 0-3296-200
	1100-1696	1	Power Cord 25' GFCI 1.5 & 2HP	0-3297-200, 0-3298-200
18	303-1715	1	Strain Relief Bushing - 25' & 6'	-200 & -203 models
	303-1120	1	Strain Relief Bushing - 3' models	-206 models
19	330-1057	4	10-16 x 5/8" Hex Washer Screw	All
20	340-2285	1	Pump Base	All
21	348-1041	4	Stem Bumpers	All
22	308-1042	2	O-Ring, Hose Adaptor	All
23	340-2290	2	Hose Adaptor	All
24	1100-1221	1	Jumper Wire 3/4-1HP models	
24	1100-1400	1	Jumper Wire 1.5-2HP models	
25	303-1109	1	Switch	
26	303-1110	1	Switch Nut	
<b>ALL MODELS</b>				
27	365-2072	1	Owner's Guide	
28	—	1	Warranty	

# EXPLODED VIEW Swimming Pool Pump

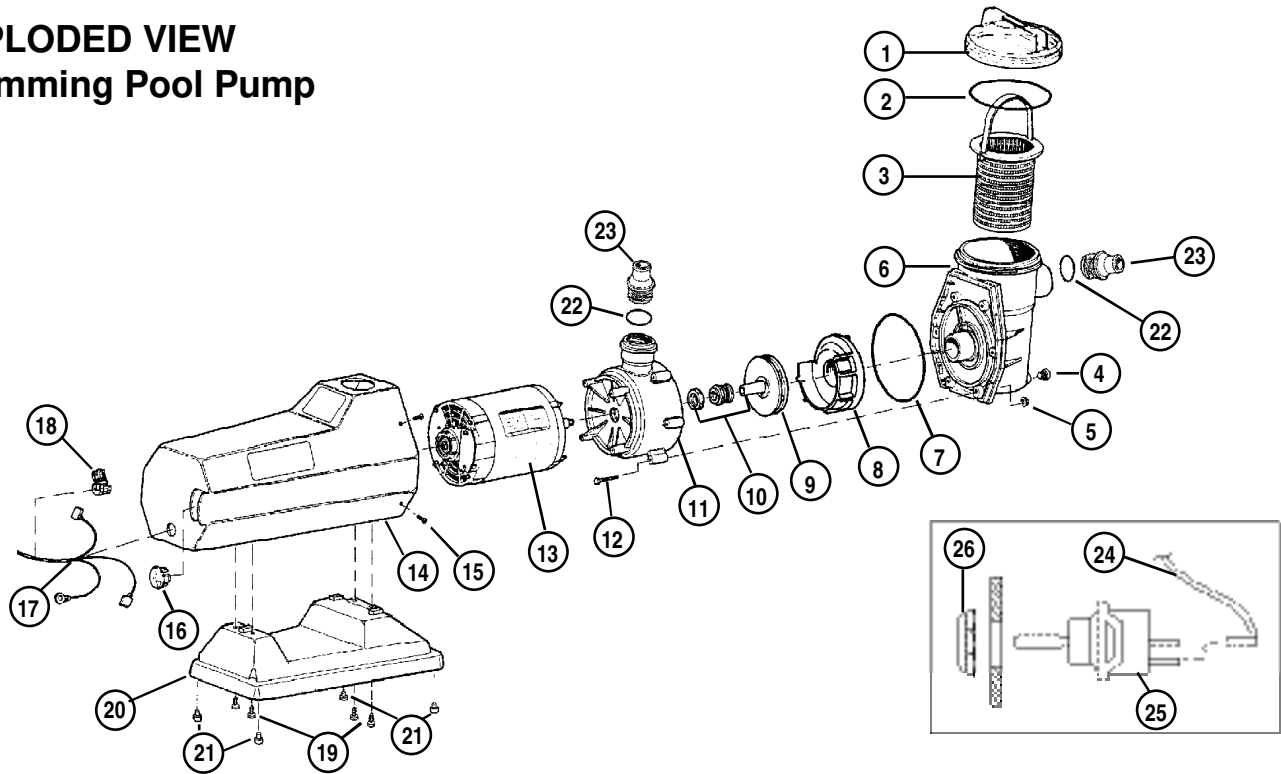

## CAUTIONS

1. Do not install pump and filter system where flooding may occur. This could damage the pump motor.
2. Do not install filter and pump on a deck, or similar surface, above pool water level. They could fall into the pool water, causing severe electrical shock.
3. Do not allow children or adults to climb, sit or stand on the filter or pump. They could easily fall and injure themselves. Install the filter and pump a minimum of 6 feet from the pool wall so they may not be used as steps by children.

## WARNINGS

1. Always be sure the ground under your feet and body is dry before you touch the filter and pump electrical equipment. Failure to follow this warning may cause injury due to severe electrical shock.
2. Make sure pump is disconnected from electrical source before servicing pump and filter equipment.

## LOCAL CODES

Contact your local building department for applicable codes or regulations governing the installation of swimming pool equipment.

## CONTRACTED ELECTRICIANS

Always have a licensed electrician install electrical components to make sure electrical integrity is maintained in accordance with the pump data label. Improper installation to power supply may damage the pump motor.



**Change of Design:** Doughboy Recreational expressly reserves the right to change or modify the design and construction of any product in due course of our manufacturing procedures, without incurring any obligation or liability to furnish or install such changes or modifications on products previously or subsequently sold.

**Doughboy Recreational**  
315 North Sebastian St. • West Helena, AR 72390  
Visit our website at [www.doughboy-pools.com](http://www.doughboy-pools.com)