

Silica I™ Plus

Rotary Sand Filter

Model 0-1741-000

Owner's Guide



Doughboy's Silica I™ Plus Filter makes routine pool care easier, faster and more convenient. Silica I™ Plus carries small particles, dust and debris out of your pool. Clean, clear, polished water is returned to the pool. This filtering system, combined with proper pool chemistry, will keep your pool sparkling. Follow the easy steps below to install your new Silica I™ Plus Filter. Numbers in parentheses refer to key numbers in the illustration on page 7.

IS YOUR POOL READY?

The pool must be properly erected per Doughboy's Pool Assembly & Installation Instructions. There should be approximately 2' of water up the metal wall so the liner is stretched to the proper position for installation of the complete filtering system (skimmer, filter, pump, etc.).

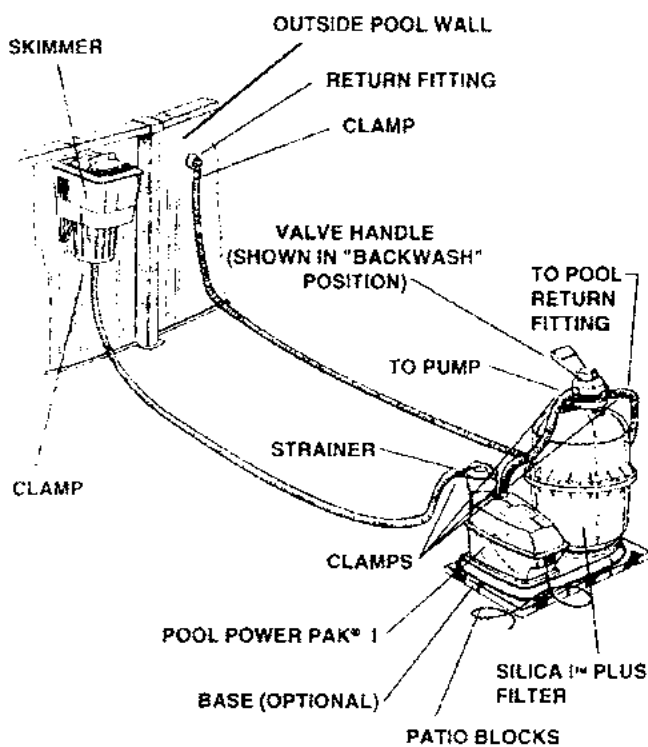

FIG. 1

Tools and Materials You Will Need

- Six 14" x 14" patio blocks
- Shovel
- 100 lbs. #20 crystal grade sand
- 7/16" Wrench
- Flat Head Screwdriver
- Phillips Screwdriver (if optional base is purchased)
- Ordinary clean plastic bag
- Medium-sized rubber band (approx. 3" lg.)
- Waste Hose - 1 1/2" Diameter
- Carpenter's level

INSTALLING SILICA I™ PLUS FILTER

Install the filter and pump approx. 5 feet from the pool wall so they may not be used as steps by children.

Filtering system must sit on a firm, level pad. Patio blocks are the best and easiest material to use for the pad. Any material that is firm and level is acceptable. This pad gives firm support to the Silica I™ Plus, and allows easy maintenance. It keeps grass from blocking air to the Pool Power Pak®, and keeps standing water away from electrical parts. Use six 14" x 14" patio blocks to make a pad large enough so the Silica I™ Plus, Power Pak and base (if purchased) can sit without tipping. (Fig. 1) Use a shovel and carpenter's level to level ground before placing blocks if necessary.

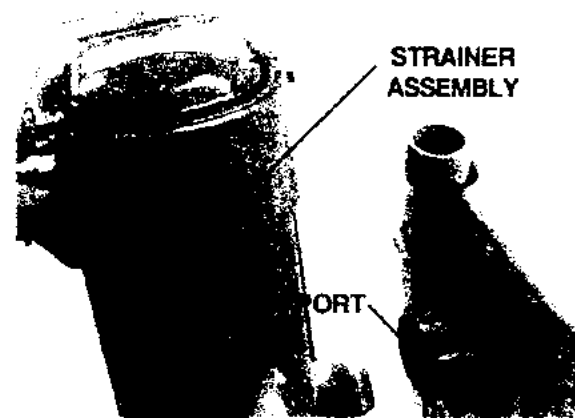

MOUNTING STRAINER ASSEMBLY ON POOL POWER PAK

Thread strainer assembly (32) into pump suction port on the Pool Power Pak. Take care to prevent cross-threading. Do not overtighten. The strainer should be snug and in an upright position. You will not use the hose fitting adaptor supplied with your Power Pak. The strainer assembly replaces it with the Silica I™ Plus Filter.

FILTER SAND

Your Silica I™ Plus Filter is designed to provide peak performance using a 20# grade crystal sand. The sand should be uniform in size, and appear as crushed sand with sharp edges. Rounded river bed sand will impair filtering performance. The technical specification is #20 Silica crystal sand.

FILLING TANK WITH SAND

The Silica I™ Plus Filter is designed to hold exactly 100 pounds of #20 crystal sand. This sand can be purchased from your local pool dealer. Remove the two bolts from the tank flange. Lift the tank cover straight up and set it aside. Place a clean plastic bag over the exposed end of the pipe extending up from the center of the tank. Secure bag with a rubber band. This will prevent sand from entering into the lower underdrain when filling the tank. (See Fig. 2).

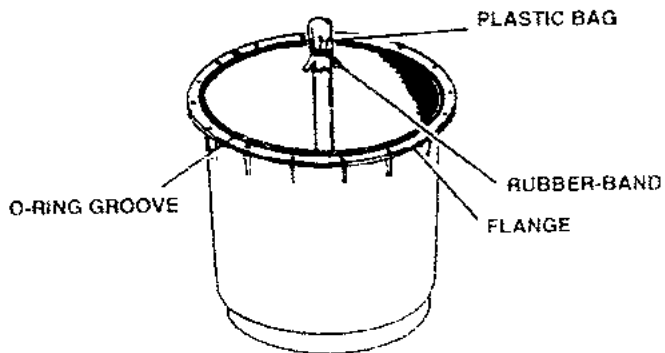

FIG. 2

Pour sand into the filter tank, distributing evenly. Stop filling about 1/2" from the top flange. Set the remainder of required sand aside for now. Clean off any sand that might be on the flange or in the O-Ring groove before installing the tank O-Ring (22) into O-Ring groove. Remove the bag and rubber band on the center pipe. Replace cover on tank aligning index tabs and sockets. Note: Index tabs must be aligned with sockets or tank cover will not seal properly (See Fig. 3)

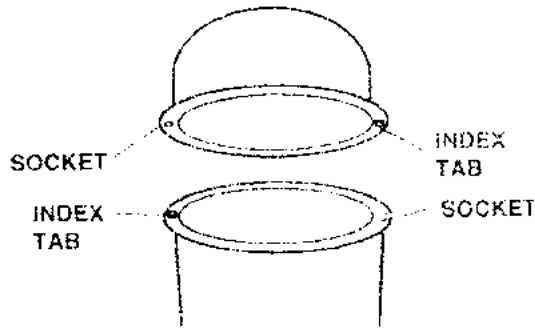

FIG. 3

Install all bolts (20), washers (21) and nuts (30). Tighten bolts and nuts in a uniform manner opposite each other while working around the tank. Remove top tank plug (17) and O-Ring (18) and set aside. Construct a funnel from heavy paper or lightweight cardboard (See Fig. 4). Place funnel in opening and pour the remaining sand directly into tank. It will be easier to use a small can instead of pouring directly from bag. When all the sand is in the tank, clean sand off plug and O-Ring seat area. Replace tank plug and O-Ring.

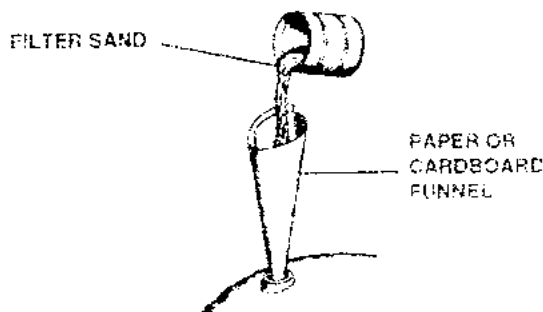

FIG. 4

HOSE INSTALLATION

(See Fig. 1 and Exploded Parts Illustration)

IMPORTANT: Incorrect hose hook-up could cause damage to your filter system. Follow the instructions below carefully.

Suction and return lines should be partially buried to prevent accidental tripping that could cause personal injury or damage to your filter system. Starting at least 12" from the pool wall, make two 3-4" deep trenches, one from the pool skimmer to the front of the pump and the other from the pool return fitting to the filter return port.

The two 8 ft. long hoses (40) are interchangeable and used for the suction and return lines. Slip a hose clamp over the ends of each hose prior to installing. Connect one long hose (suction line) between the pool skimmer and front port of the pump. Connect the other long hose (return line) between the pool return fitting and the filter return port. Connect the short hose (6) between the pump discharge port (located at top of pump) and the filter return port. Tighten clamps firmly using a flathead screwdriver or 5/16" nutdriver. Cover the trenches with a firm board when finished.

NOTE: Do not completely bury the long hoses with dirt.

SILICA™ PLUS OPERATING POSITIONS

Your new Silica™ Plus Filter has four positions of operation, which are explained below. To change positions on the filter, make sure the pump is "OFF". Press down on the filter handle enough to free the locking tab. Rotate the handle so the tab locks in the desired position. The locking tab indicates the filter position. The tab must be locked into one of the four slots for the filter to operate correctly (Fig. 5). See **Initial Start-Up and Operation of Filter** for instructions on how to operate the filter.

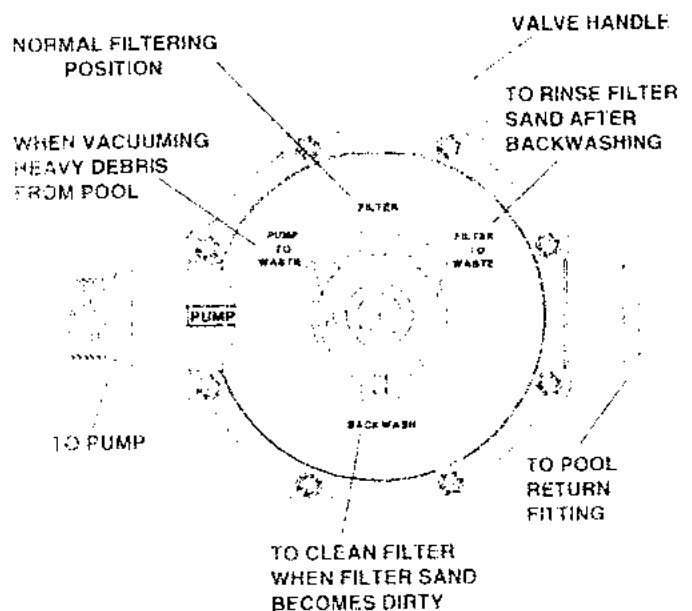

FIG. 5

FILTER POSITION

(Normal running position for filtering pool water.) The length of filtering time depends on: pool size, pool use, amount of airborne dust and debris, and chemical treatment. High wind locations will cause a pool to get dirty faster, requiring longer filtering time. Failure to give your pool proper chemical treatment will also require additional filtering time. Your pool dealer can help you determine proper filtering times, general maintenance and chemical treatment for your pool.

BACKWASH POSITION

During the filtering process, suspended contaminants accumulate in the filter sand. This will cause the pressure to rise and the return water flow to diminish. Backwashing reverses the flow of water, cleaning dirt and debris from the filter. How often you backwash the filter will vary with pool size, pool use, amount of airborne dirt and debris, and the chemical treatment you give the water. Backwashing should be done when the Silica I™ Plus pressure gauge reads 5 to 7 pounds higher than initial start-up pressure. Example: If the pressure gauge reads 10 pounds at the start of a clean filter, you should backwash when the gauge reads from 15 to 17 pounds. See Initial Start-Up and Operation section for backwashing instructions.

FILTER TO WASTE POSITION

Place the valve handle in the FILTER TO WASTE position after backwashing your Silica I™ Plus Filter. This will prevent an objectionable "cloudy puff" of debris from entering your pool through the pool return inlet.

PUMP TO WASTE POSITION

This position allows you to vacuum heavy debris or larger amounts of settled contaminants from the bottom of your pool directly to waste.

INITIAL START-UP AND OPERATION OF FILTER

The water level in your pool must be between the water level markers on the skimmer faceplate. The pump must be able to draw water from the pool to operate safely. Never run the pump with the pool water level so low that no water passes to the pump. The pump seal may overheat and permanent damage to the pump may occur.

BACKWASHING FILTER

Waste Line Hook-Up: Be sure the pump is "OFF". Remove the drain cap (37) and gasket (38) from the filter. Connect a 1 1/2" dia. hose to the waste port. (A collapsible type can be purchased from your pool dealer, or use a 1 1/2" pool vacuum hose.) Place the other end of the hose in a drainage area. **CAUTION:** Chlorine kills lawns and plant life. The hose will deliver about 100 gallons of water from your filter to the drainage area. Choose the drainage area carefully.

Rotate valve handle to the BACKWASH position. Start the pump. Allow the filter to backwash for at least four to five minutes to remove fine particles and impurities in

the new filter sand. Stop pump. Rotate valve handle to FILTER TO WASTE position. Start the pump and run for 10 seconds. Stop pump. Remove waste hose and replace gasket (38) and drain cap (37).

FILTERING

Rotate valve handle to FILTER position. Start pump. Note the reading on the pressure gauge. This reading is your clean filter start-up pressure. You will use this reading to determine when it is time to clean your Silica I™ Plus Filter. (See "BACKWASH POSITION" in this guide.)

A newly filled pool usually requires continuous filtering for about 24 hours. The time varies depending on water conditions and amount of water being filtered. During initial start-up, the Silica I™ Plus may require frequent cleaning (backwashing) as it filters the water. (See "BACKWASH POSITION".) Operate the Silica I™ Plus and pump for two days after initial start-up. Then check all fittings, clamps, and screws for tightness. Retighten where necessary.

ROUTINE CARE & MAINTENANCE KEEP YOUR POOL SPARKLING

You can take steps to reduce the amount of maintenance needed to keep your pool sparkling.

1. Provide a clean walkway leading to your pool entrance.
2. Rinse off patio and area around pool regularly.
3. Pool users should rinse off (especially their feet) before entering pool.
4. Maintain the proper chemical balance in your pool. Hot days will cause chemicals to dissipate rapidly.
5. Remove floating leaves and debris with a leaf skimmer.
6. Empty skimmer basket frequently.
7. Vacuum pool bottom to remove settled debris.
8. A pool cover will help keep your pool clean during high winds or rainfall.

DOUGHBOY POOL CARE

Refer to Doughboy's "SAFETY FIRST Pool Use Handbook" for correct use, care, and chemical treatment of Doughboy pools.

CHLORINE INSTRUCTIONS ALWAYS READ AND FOLLOW CHEMICAL MANUFACTURER'S

SAFETY PRECAUTIONS FOR HANDLING CHLORINE
WARNING! Do Not Place Chlorine Tablets In The Skimmer Basket! Putting chlorine tablets directly into the skimmer basket will destroy the pump strainer basket and internal components. We recommend against adding any kind of chemicals directly into the skimmer!

Please read the following instructions carefully.

Chlorine is a strong chemical. Improper use could result in serious, permanent damage to the pool liner. This damage could include "white spots", wrinkles or breakage (brittle vinyl). Such damage is not covered under warranty.

IMPORTANT: Pump and Silica I™ Plus should always be "ON" when adding any chemicals to pool water.

WITH DISPENSER

Dry Chlorine (tablets, sticks, granules, or powder). Use one of the following types of chlorine dispensers:

- Floating Dispenser: Use only when pump and Silica I™ Plus are running. Dispenser must circulate in pool for safe distribution of chlorine.
- Automatic feeder (in-line or off-line).
- Chlorine generator - Approved for use. Releases chlorine from salt.

Ask your Doughboy dealer to recommend the best type of dispenser for your pool and area conditions. Follow manufacturer's instructions for correct use.

WITHOUT DISPENSER

Dry Chlorine: Use granules or powder only. NEVER pour dry chlorine directly into the pool water. Mix with pool water in a clean plastic container following chlorine manufacturer's safety instructions. When all chlorine has dissolved, pour solution into pool water at the return fitting. Water returning to the pool will properly distribute chlorine.

Liquid Chlorine: Liquid chlorine concentrate may be poured directly into pool water. Carefully add liquid chlorine to water at the return fitting. Water returning to the pool will distribute the chlorine. Follow chemical manufacturer's instructions for use of liquid chlorine.

TO CLEAN DOUGHBOY STRAINER ASSEMBLY

CLEAN THE STRAINER ASSEMBLY FREQUENTLY. The strainer assembly on the Doughboy Pool Power Pak® catches large debris such as insects and leaves. **To clean:** Stop your Power Pak. Rotate valve handle on Silica I™ Plus to BACKWASH position. This closes off the pool return line to prevent back flow of water through the filter and out the pump strainer. To prevent water coming from the skimmer, remove skimmer lid and basket. Plug the hole in the bottom of the skimmer with a towel or cloth. Rotate strainer assembly lid counter-clockwise until locking tabs are free. Lift off the cover. Remove basket and clean. Lubricate O-Ring on cover prior to reassembly. (See "LUBRICATION" in this guide.) Replace strainer basket. Replace strainer lid and turn clockwise until tabs lock into place. Remove towel or cloth from skimmer hole. Replace skimmer basket and lid. Rotate valve handle to FILTER position and start your pool Power Pak to resume normal filter operation.

LUBRICATION

Important: Regularly lubricate the O-Ring on the

Power Pak strainer assembly cover with a NON-PETROLEUM lubricant recommended for A.B.S., Noryl and Acrylic plastics. Consult your pool dealer for lubricant selections. To lubricate the O-Ring on the shaft attached to the valve handle, stop pump. Depress valve handle fully and apply lubricant. Rotate handle to distribute lubricant. To resume normal filtering operation, rotate valve handle to FILTER position and start pump.

VACUUMING YOUR POOL

Prior to vacuuming, clean out strainer assembly basket on your Power Pak and backwash your Silica I™ Plus Filter thoroughly. Follow skimmer manufacturer's instructions for vacuuming pool. It may be necessary to backwash your filter frequently during the vacuuming operation. For excessive amounts of dirt on the pool floor, we recommend that you vacuum directly to waste. This is accomplished by installing your wasteline (See Wasteline Hookup under Backwashing section) and placing the filter valve handle in the PUMP TO WASTE position. Then proceed vacuuming as usual. When you've completed vacuuming, backwash your Silica I™ Plus thoroughly and clean the strainer basket again. Resume normal filtering operation.

WINTERIZING (FREEZING CLIMATES)

With Doughboy Skimmer & Return Fitting

Your Silica I™ Plus Filter must be drained, cleaned and stored indoors for the winter season. We strongly recommend, for the protection of your filter, liner and pool wall, that you purchase and install the DOUGHBOY Winterizing Kit (0-2099-001). The proper installation of this kit will allow the removal and storage of your skimmer and filter, and should eliminate any possibility of damage due to winter peril.

CAUTION

Removing the skimmer without installing a winterizing kit is very dangerous to the pool wall, liner and pool installation, and voids any warranty. Filter damage caused by freezing temperatures is not covered by product warranty.

To winterize Silica I™ Plus: Drain pool water to 6" below return fitting. Rotate valve handle to PUMP TO WASTE position (See Pump To Waste). Turn pump on and run until water level is drawn down to skimmer level. Turn pump "OFF". Additional water removal can be accomplished by syphoning with several garden hoses or vacuum hoses.

Remove bottom tank plug (17) and loosen top tank plug to relieve air. Remove tank flange bolts (20), washers (21), and nuts (30). Lift cover off and set aside. Secure a clean plastic bag with a rubber band over pipe opening extending up from center of tank. Scoop sand out with a medium size can. Place sand in a plastic trash can and save for next season's use. If the sand is badly contaminated, discard it and purchase new sand next season.

Store your pump and Silica 1™ Plus indoors for the winter season. Filter or pump damage caused by freezing temperatures is not covered by product warranty. For spring start-up, follow Filling Tank, Hose Installation and Initial Start-Up instructions in this guide.

TROUBLE SHOOTING

- A. High gauge pressure, low return flow.**
1. Filter sand is too fine. (Use #20 crystal sand.)
 2. Or, excessive contaminants or algae in sand.
 3. Or, underdrain plugged due to fine sand. (Use #20 crystal sand.)
 4. Or, insufficient backwashing. Backwash thoroughly.
- B. Low gauge pressure, low flow. Pump suction is drawing in air (noted by bubbles returning to pool), or pump sounds like marbles are rattling in it.**
1. Pool water level is too low. SWITCH PUMP "OFF" AT ONCE. Fill pool so water level is between markers on skimmer faceplate.
 2. Or, there is a restriction on the suction side of the pump.
 3. Or, pump strainer assembly is clogged with debris. Clean strainer assembly.
- C. High flow, low or normal gauge pressure...but pool water won't clear up.**
1. Pool water is chemically out of balance. Use water test kit to check balance.
 2. Or, sand is too coarse. (Use #20 crystal sand.)
 3. Or, rounded type sand used. (Use #20 crystal sand.)

- D. Very short filtering cycles.**
1. Backwash filter thoroughly.
 2. Sand may be too fine. (Use #20 crystal sand.)
 3. Or, excessive suspended contaminants or algae in sand.
 4. Or, excessive suspended contaminants or algae in pool water. (Filter will require frequent backwashing until pool clears up.)
- E. Cloudy puff coming out of return fitting.**
1. Place valve handle in FILTER TO WASTE position when turning on pump and after backwashing.
 2. Or, if vacuuming, place valve handle in PUMP TO WASTE position.
- F. Water is leaking to waste.**
1. Inspect drain cap (37) and gasket (38) for needed repair.
 2. Actuate and rotate valve handle to clear sealing area of debris.
 3. Or, replace valve gasket in valve cover.
- G. Filter is backwashing when valve handle is in FILTER position after servicing filter.**
1. Valve cover is assembled backwards on tank cover (180° from correct position).

SERVICE

During disassembly of the filter, mark each part's assembled position as it relates to the mating part to assure proper alignment when reassembled. Malfunctioning of the filter will occur if not properly reassembled. Use only original Doughboy replacement parts. See your professional Doughboy pool dealer for Original Equipment Manufactured (OEM) parts and servicing.

PARTS LIST SILICA 1™ PLUS- MODEL 0-1741-000

ITEM	P/N	QTY	DESCRIPTION	ITEM	P/N	QTY	DESCRIPTION
1	340-1764	1	Valve Handle	22	308-1113	1	Tank "O" Ring
2	376-1050	1	Handle Pin	23	340-1285	1	Adaptor
3	327-1007	2	Friction Washer-Lg	24	343-1100	1	Air Relief
4	330-1174	8	#10-24 x 1" Hex Hd Screw	25	340-1284	1	Distributor Body
5	387-1017	6	1 1/2" Hose Clamp	26	340-1288	1	Distributor Dish
6	346-1013-1	1	1 1/2" x 2 1/2" Hose	27	330-1023	10	#8 - 5/8" Hex Hd. Screw
7	340-2026	1	Valve Cover	28	1107-1038	1	Underdrain Assy.
8	395-1014	1	Pressure Gauge	29	340-1554	-	Tank
9	308-1174	1	"O"-Ring	30	321-1021	16	1/4" - 20 Hex Flange Nut
10	327-1006	2	Valve Bearing Washer	31	340-1201	1	Sand Filter Drain
11	396-1023	1	Valve Spring	32	1300-1014	1	Strainer Assy
12	340-1766	1	Valve Rotor	33	1121-1436	1	Strainer L.d.w.Decal
13	308-1182	1	Gasket, Valve Rotor	34	308-1004	1	Strainer "O" Ring
14	1107-1384	1	Valve Body & Gasket Assy.	35	1300-1002	1	Strainer Basket Assy
15	321-1054	8	#10-24 Square Nut	36	340-1779	1	Strainer Body
16	308-1109	2	Valve Port Gasket	37	340-1035	1	Drain Cap
17	340-1183	2	Tank Plug	38	307-1001	1	Drain Cap Gasket
18	308-1043	2	"O"-Ring	39	340-1826	2	Friction Washer-Sm.
19	1121-1329	1	Tank Cover w/Decal	40	346-1035-1	2	1 1/2" x 8" Hose
20	324-1020	16	1/4-20 x 1 1/4" Hex Hd Bolt	41	—	1	Warranty Card
21	326-1008	16	1/4" Plain Washer	42	365-1922	1	Owners Guide

* NOTE: Item 14 includes item 13.

EXPLODED PARTS

Model 0-1741-000

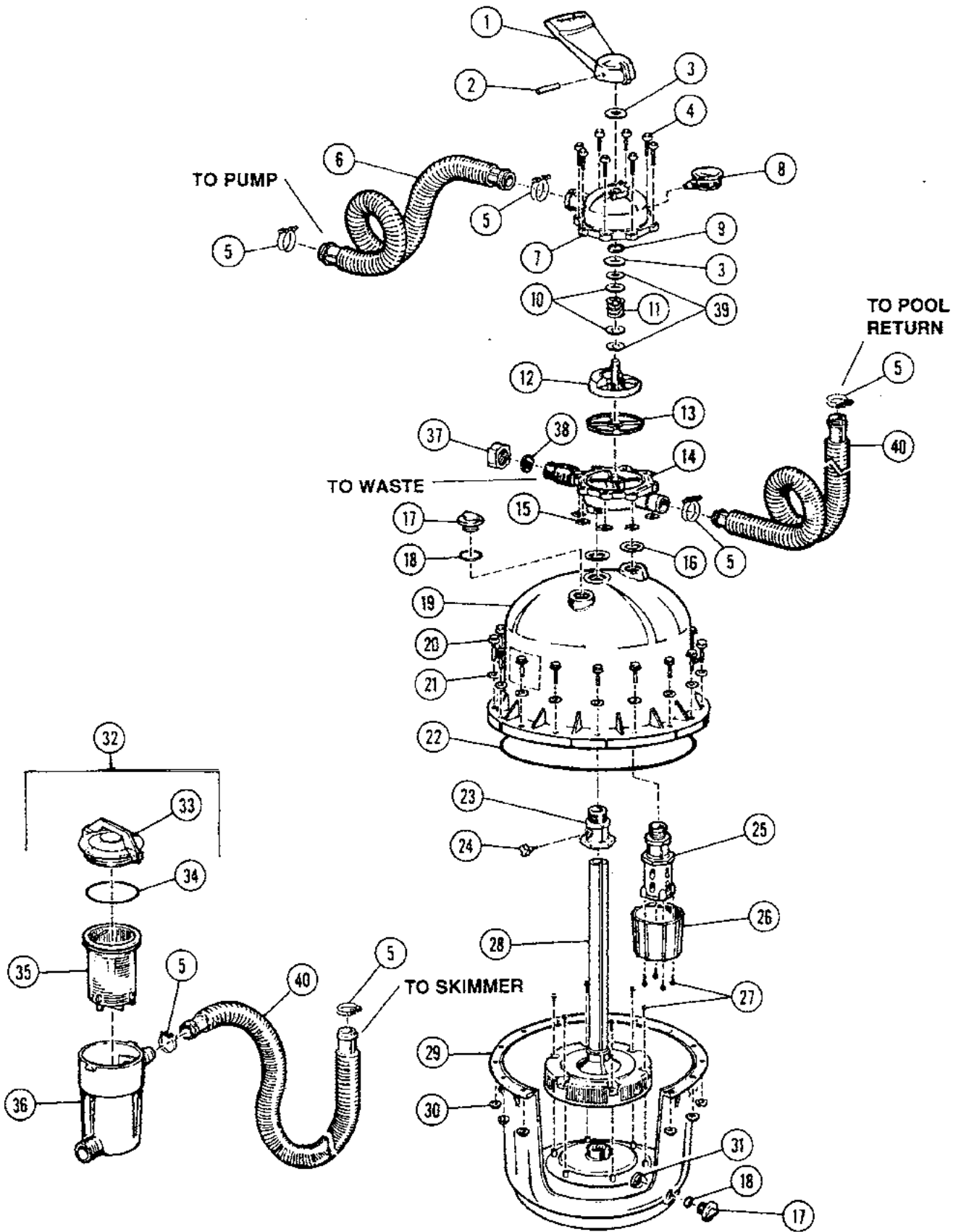

IMPORTANT FILTER/PUMP SAFETY

1. **DO NOT** install filter or pump on a deck. They could fall into the water, causing severe electrical shock. Do not install on any surface at, above, or slightly below the top rail of the pool.
2. **DO NOT** allow children or adults to climb, sit or stand on the filter or pump units. They could easily fall. Position filter and pump approximately 5 feet from the pool wall so they may not be used as steps by children.

SERVICING SAFETY TIPS

- A. **ALWAYS TURN "OFF"** the main power switch and the Ground Fault Circuit Interrupter (GFCI) breaker switch so power is completely off before servicing your unit.
- B. **ALWAYS STOP PUMP** before you service, tighten, or adjust the filter assembly.
- C. **ALWAYS BE SURE THE GROUND UNDER YOUR FEET, AND YOUR BODY, IS DRY** before you touch electrical equipment. Failure to heed this warning may cause personal injury due to severe electrical shock.

- D. **ALWAYS** have a qualified electrician service your system if electrical problems occur.
- E. **ALWAYS** have a qualified electrician install a Ground Fault Circuit Interrupter (GFCI) breaker at the electrical service or supply panel. Follow GFCI manufacturer's operating instructions for testing. Failure to do so may cause serious permanent personal injury due to severe electrical shock.

CAUTION: To reduce the risk of electrical shock, connect only to grounding type receptacles. A Ground Fault Circuit Interrupter (GFCI) must be provided in accordance with Article 680 of the National Electrical Code (NEC) and local codes or ordinances.

CAUTION: To reduce the risk of electrical shock, use only Original Equipment Manufactured (OEM) replacement parts when servicing.

Change of Design: Doughboy Recreational expressly reserves the right to change or modify the design and construction of any product in due course of our manufacturing procedures, without incurring any obligation or liability to furnish or install such changes or modifications on products previously or subsequently sold.



DOUGHBOY RECREATIONAL • 315 North Sebastian Street, • West Helena, AR 72390