

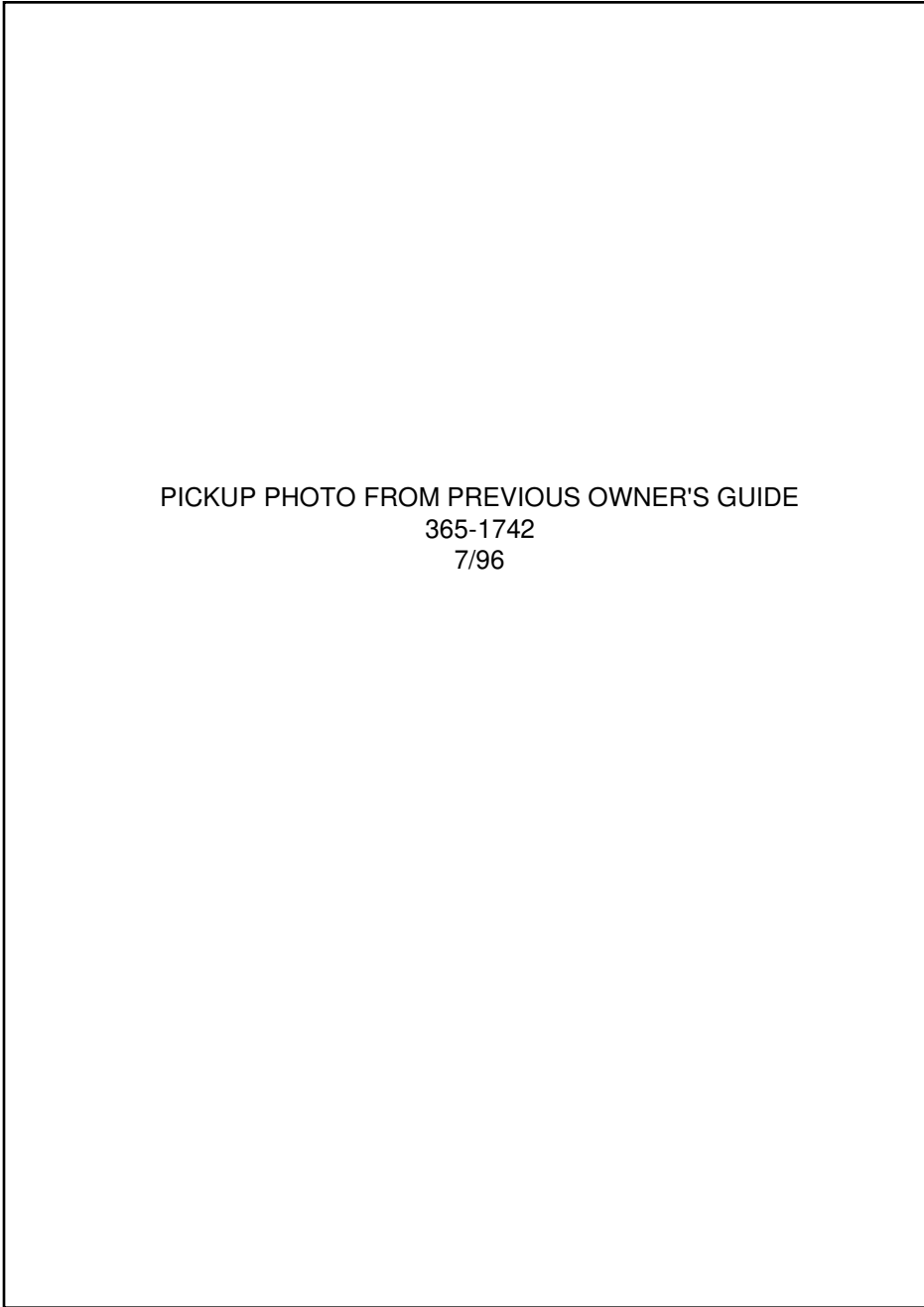

Silica II™

Rotary Sand Filter
Model 0-1750-000

Owner's Guide



PICKUP PHOTO FROM PREVIOUS OWNER'S GUIDE
365-1742
7/96



“READ ALL INSTRUCTIONS” Failure to follow these important safety instructions and other basic safety precautions may result in serious personal injury.

IMPORTANT SAFETY INSTRUCTIONS

Before you begin installing your filter, refer to your pump owner's guide for very important installation and electrical information related to your filter.

ELECTRICAL/BUILDING PERMIT

Local building codes may require obtaining an electrical or building permit and may have regulations on setbacks and barriers that **must** be followed.

ELECTRICAL

We recommend you have a qualified electrical contractor install the electrical power supply as specified in your pump instructions.

INSTALLED LOCATION

Position filter, pump and any other related components a minimum of 5 feet from pool to prevent their being used as a means to climb into the pool by young children. **DO NOT** store toys, chairs, tables, containers or other objects within 5 feet of the pool for the same reason.

WARNING

SEVERE ELECTRICAL SHOCK could result if you install your filter and pump on a deck or above pool water level. They could fall into the water, causing severe shock or electrocution. **DO NOT** install on a deck or other surface at, above or slightly below the top rail of the pool.

PROPERLY SUPPORTED

Filter, pump and any other related components should be properly supported to prevent damage from misalignment, settlement or vibration, and mounted to minimize the potential for the accumulation of debris and moisture.

ACCESSIBILITY

The circulation system components should be installed to allow accessibility for inspection, repair, or replacement.

DO NOT alter the pump electrical cord in any way or change the plug end to any other style.

DO NOT use an extension cord(s). Severe electrical shock may occur.

PREVENT SEVERE SHOCK

To prevent the risk of severe electrical shock, plug your pump cord end into a grounding type receptacle protected by a ground fault circuit interrupter (GFCI). Contact a qualified electrician if you cannot verify that the receptacle is protected by a GFCI.

DO NOT allow children to operate or play around this

product unless they are closely supervised by adults at all times.

Replace damaged cord immediately to reduce the risk of electrical shock.

DO NOT BURY CORD

An exposed cord may accidentally become damaged or severed by a sharp object or shovel resulting in severe electrical shock. Position cord to prevent accidental damage from lawn mowers, hedge trimmers, or other equipment.

BARE FEET/WET GROUND

This is a dangerous combination around electrical equipment. Always be sure the ground under your feet and body is dry before you touch electrical equipment. Failure to heed this warning may cause severe personal injury or electrocution due to severe electrical shock.

WARNING

Avoid direct water spraying with a garden hose around electrical outlets, pump or any other electrical devices. Severe electrical shock or electrocution may occur.

SERVICING YOUR PUMP

Always unplug your pump from the receptacle before servicing, adjusting or repairing your filter system.

CAUTION: To reduce the risk of electrical shock, use only Original Equipment Manufactured (OEM) replacement parts when servicing.

Did you read the **IMPORTANT SAFETY INSTRUCTIONS?** If not, **READ THEM NOW.** They contain very important safety information related to the installation of your filter.

Familiarize yourself with the installation sequences by reading these instructions first. **AVOID SHORTCUTS** that may result in reworking the installation.

Doughboy's Silica II™ Filter makes routine pool care easier, faster, and more convenient. Silica II™ carries small particles, dust and debris out of your pool. This debris, with the water, is processed through a special filtering sand. Clean, clear, polished water is returned to the pool. This filtering system, combined with proper pool chemistry, will keep your pool sparkling. Follow the easy steps below to install your new Silica II™ Filter. Numbers in parentheses refer to key numbers in the illustration on page 7.

IS YOUR POOL READY?

The pool must be properly erected per Doughboy's Pool Assembly & Installation Instructions. There should be approximately 2' of water up the metal wall so the liner is stretched to the proper position for installation of the complete filtering system (skimmer, filter, pump, etc.).

Tools and Materials You Will Need

- Six 14" x 14" patio blocks
- Shovel
- 130 lbs. #20 crystal grade sand
- 7/16" Wrench
- Flat Head Screwdriver
- 5/16" Nutdriver (optional)
- Phillips Screwdriver (if optional base is purchased)
- Ordinary clean plastic bag
- Medium-sized rubber band (approx. 3" Lg.)
- Waste Hose - 1 1/2" Diameter
- Carpenter's Level

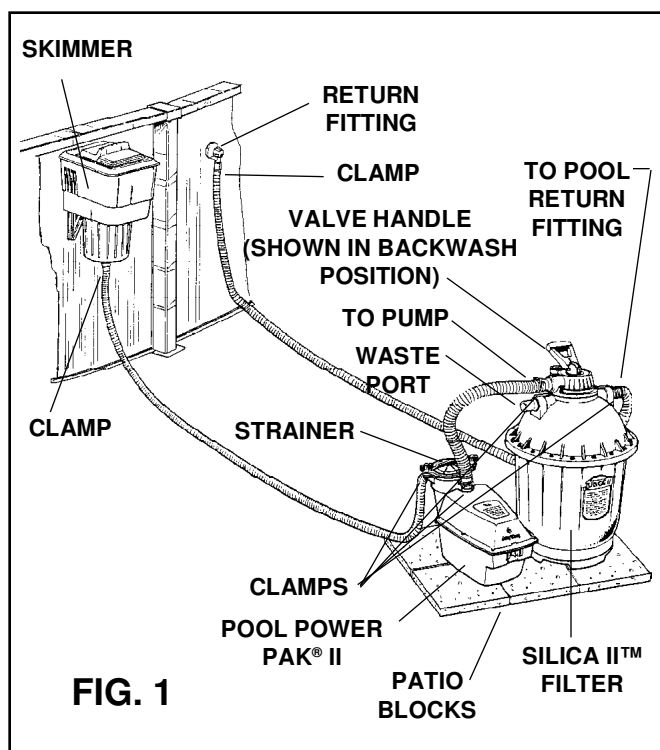

INSTALLING SILICA II™ FILTER

Install the filter and pump approximately 5 feet from the pool wall so that they may not be used as steps by children.

FILTERING SYSTEM MUST SIT ON A FIRM, LEVEL PAD. Patio blocks are the best and easiest material to use for the pad. Any material that is firm and level is acceptable. This pad gives firm support to the Silica II™, and allows easy maintenance. It keeps grass from blocking air to the pump, and keeps standing water away from electrical parts. Use six 14" x 14" patio blocks to make a pad large enough so the Silica II™, pump and base (if purchased) can sit without tipping. Use a shovel and carpenter's level to level ground before placing blocks if necessary.

FILTER SAND

Your Silica II™ Filter is designed to provide peak performance using a #20 grade crystal sand. The sand should be uniform in size, and appear as crushed sand with sharp edges. Rounded river bed sand will impair filtering performance. The technical specification is #20 crystal sand.

FILLING TANK WITH SAND

The Silica II™ Filter is designed to hold exactly 130 pounds of #20 crystal sand. This sand can be purchased from your local pool dealer. Remove the two bolts (16) from the tank flange. Lift the tank cover straight up and set it aside. Place a clean plastic bag over the exposed end of the pipe extending up from the center of the tank. Secure bag with a rubber band. This will prevent sand from entering into the lower underdrain when filling the tank.

Pour sand into the filter tank, distributing evenly. Stop filling about 1/2" from the top flange. Pour the remainder of required sand around center pipe. Clean off any sand that might be on the flange or in the flange O-Ring groove before installing the tank O-Ring (22) into tank flange groove. Remove the rubber band and bag on center pipe. Replace cover on tank. Install all bolts (16) and nuts (28). Tighten bolts and nuts in a uniform manner opposite each other while working around the tank.

HOSE INSTALLATION

(See Fig. 1 and Exploded Parts Illustration)

IMPORTANT: Incorrect hose hook-up could cause damage to your filter system. Follow the instructions below carefully.

Suction and return lines should be partially buried to prevent accidental tripping that could cause personal injury or damage to the filter system.

Starting at least 12" from the pool wall, make two 3-4" deep trenches, one from the pool skimmer to the front of the pump and the other from the pool return fitting to the filter return port.

The two 8 ft. long hoses (33) are interchangeable and used for the suction and return lines. Slip a hose clamp over the ends of each hose prior to installing. Connect one long hose (suction line) between the pool skimmer and front port of the pump. Connect the other long hose (return line) between the pool return fitting and filter return port. Connect the short hose (32) between the pump discharge port (located at top of pump) and the filter pump port. Tighten clamps firmly using a flathead screwdriver or 5/16" nutdriver. Cover the trenches with a firm board when finished.

NOTE: Do not completely bury the hoses with dirt.

SILICA II™ OPERATING POSITIONS

Your new Silica II™ Filter has six positions of operation, which are explained below. To change positions on the filter, make sure the pump is "OFF". Press down on the filter handle enough to free the locking tab. Rotate the

handle so the tab locks in the desired position. The locking tab indicates the filter position. The tab must be locked into one of the six slots for the filter to operate correctly (FIG. 2).

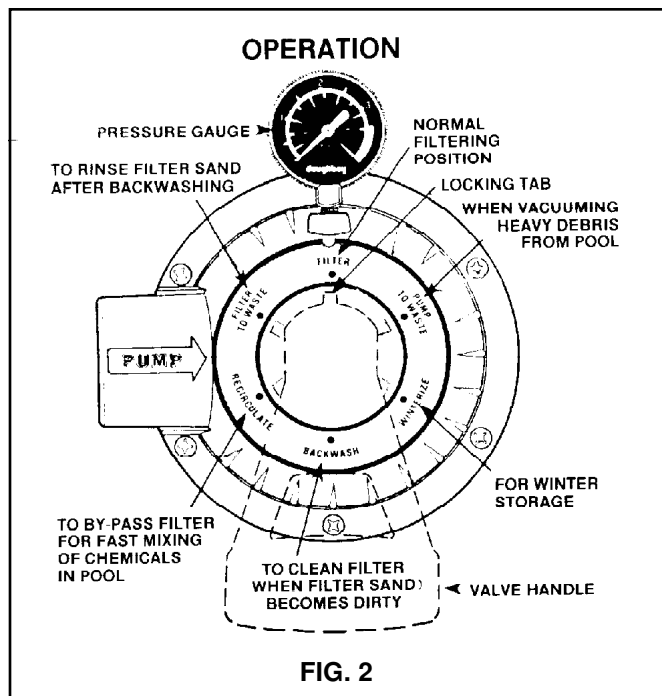

FIG. 2

FILTER POSITION

(Normal running position for filtering pool water.)

The length of filtering time depends on: pool size, number of pool users, amount of airborne dust and debris, and chemical treatment. High wind locations will cause a pool to get dirty faster, requiring longer filtering time. Failure to give your pool proper chemical treatment will also require additional filtering time. Your pool dealer can help you determine proper filtering times, general maintenance and chemical treatment for your pool.

BACKWASH POSITION

During the filtering process, suspended contaminants accumulate in the filter sand. This will cause the pressure to rise and the return water flow to diminish. Backwashing reverses the flow of water, cleaning dirt and debris from the filter. How often you backwash the filter will vary with pool size, pool use, amount of airborne dirt and debris, and the chemical treatment you give the water. Backwashing should be done when the Silica II™ pressure gauge reads 5 to 7 pounds higher than initial start-up pressure. Example: If the pressure gauge reads 10 pounds at the start of a clean filter, you should backwash when the gauge reads from 15 to 17 pounds.

FILTER TO WASTE POSITION

Place the valve handle in the "Filter to Waste" position after backwashing your Silica II™ Filter. This will prevent an objectionable "cloudy puff" of debris from entering your pool through the pool return inlet.

PUMP TO WASTE POSITION

This position allows you to vacuum heavy debris or larger amounts of settled contaminants from the bottom of your pool directly to waste.

RECIRCULATE POSITION

This position allows you to increase the water flow rate through the filter to circulate chemicals throughout the pool more quickly. Pool water passes through the filter valve on top of the filter, bypassing internal filter components, and travels back to the pool at a rapid rate.

WINTERIZE POSITION

This position allows you to drain trapped water from the filter valve and relieve compression on the rotor valve gasket during winter storage.

INITIAL START-UP AND OPERATION OF FILTER

The water level in your pool must be between the water level markers on the skimmer faceplate. The pump must be able to draw water from the pool to operate safely. Never run the pump with the pool water level so low that no water passes to the pump. The pump seal may overheat and permanent damage to the pump may occur.

Waste Line Hook-Up: Be sure the pump is "OFF". Remove the drain cap (19) and gasket (18) from the filter. Connect a 1 1/2" waste hose to the port labeled "To Waste". (A collapsible type can be purchased from your pool dealer, or use a 1 1/2" pool vacuum hose.) Place the other end of the hose in a drainage area. CAUTION: Chlorine kills lawns and plant life. The hose will deliver about 100 gallons of water from your filter to the drainage area. Choose the drainage area carefully.

Backwash Filter: Rotate valve handle to the BACKWASH position. Start the pump. Allow the filter to backwash for at least four to five minutes to remove fine particles and impurities in the new filter sand. Stop pump. Rotate valve handle to **FILTER TO WASTE** position. Start the pump and run for 10 seconds. Stop pump.

Filter Position: Rotate valve handle to FILTER position. Start pump. Note the reading on the pressure gauge. This reading is your clean filter start-up pressure. You will use this reading to determine when it is time to clean your Silica II™ Filter. (See "BACKWASH POSITION" in this guide.)

A newly filled pool usually requires continuous filtering for about 24 hours. The time varies depending on water conditions and amount of water being filtered. During initial start-up, the Silica II™ may require frequent cleaning (backwashing) as it filters the water. (See "BACKWASH POSITION"). Operate the Silica II™ and

pump for two days after initial start-up. Then check all fittings, clamps, and screws for tightness. Retighten where necessary.

ROUTINE CARE & MAINTENANCE KEEP YOUR POOL SPARKLING

You can take steps to reduce the amount of maintenance needed to keep your pool sparkling.

1. Provide a clean walkway leading to your pool entrance.
2. Rinse off patio and area around pool regularly.
3. Pool users should rinse off (especially their feet) before entering pool.
4. Maintain the proper chemical balance in your pool. Hot days will cause chemicals to dissipate rapidly.
5. Remove floating leaves and debris with a leaf skimmer.
6. Empty skimmer basket frequently.
7. Vacuum pool bottom to remove settled debris.
8. A pool cover will help keep your pool clean during high winds or rainfall.

DOUGHBOY POOL CARE

Refer to Doughboy's "SAFETY FIRST Pool Use Handbook" for correct use, care, and chemical treatment of Doughboy pools.

CHLORINE INSTRUCTIONS

ALWAYS READ AND FOLLOW CHEMICAL MANUFACTURER'S

SAFETY PRECAUTIONS FOR HANDLING CHLORINE

WARNING! Do Not Place Chlorine Tablets In The Skimmer Basket! Putting chlorine tablets directly into the skimmer basket will destroy the pump strainer basket and internal components. We recommend against adding any kind of chemicals directly into the skimmer!

Please read the following instructions carefully.

Chlorine is a strong chemical. Improper use could result in serious, permanent damage to the pool liner. This damage could include "white spots", wrinkles or breakage (brittle vinyl). Such damage is not covered under warranty.

IMPORTANT: Pump and Silica II™ should always be "ON" when adding any chemicals to pool water.

WITH DISPENSER

Dry Chlorine (tablets, sticks, granules, or powder). Use one of the following types of chlorine dispensers:

- Floating Dispenser: Use only when pump and Silica II™ are running. Dispenser must circulate in pool for safe distribution of chlorine.
- Automatic feeder (in-line or off-line).
- Chlorine generator - Approved for use. Releases chlorine from salt.

Ask your Doughboy dealer to recommend the best type of dispenser for your pool and area conditions. Follow manufacturer's instructions for correct use.

WITHOUT DISPENSER

Dry Chlorine: Use granules or powder only. NEVER pour dry chlorine directly into the pool water. Mix with pool water in a clean plastic container following chlorine manufacturer's safety instructions. When all chlorine has dissolved, pour solution into pool water at the return fitting. Water returning to the pool will properly distribute chlorine.

Liquid Chlorine: Liquid chlorine concentrate may be poured directly into pool water. Carefully add liquid chlorine to water at the return fitting. Water returning to the pool will distribute the chlorine. Follow chemical manufacturer's instructions for use of liquid chlorine.

TO CLEAN DOUGHBOY STRAINER ASSEMBLY

CLEAN THE STRAINER ASSEMBLY FREQUENTLY.

The strainer assembly on the Doughboy Pool Power Pak® catches large debris such as insects and leaves.

To clean: Stop your Power Pak. Rotate valve handle on Silica II™ to **BACKWASH** position. This closes off the pool return line to prevent back flow of water through the filter and out the pump strainer. To prevent water coming from the skimmer, remove skimmer lid and basket. Plug the hole in the bottom of the skimmer with a towel or cloth. Place one hand on top of the strainer cover and loosen the two knobs enough to rotate the cover counter-clockwise until it stops. Lift off the cover. Remove basket and clean. Lubricate O-Ring on cover prior to reassembly. (See "LUBRICATION" in this guide.) Replace basket. To replace cover, press down and rotate clockwise until slots in cover are completely under knobs. Tighten knobs until cover is fully seated. Remove towel or cloth from skimmer hole. Replace skimmer basket and lid. Rotate valve handle to **FILTER** position and start your pool Power Pak to resume normal filter operation.

LUBRICATION

Important: Regularly lubricate the O-Ring on the Power Pak strainer assembly cover with a NON-PETROLEUM lubricant recommended for A.B.S., Noryl and Acrylic plastics. Consult your pool dealer for lubricant selections. To lubricate the O-Ring on the shaft attached to the valve handle, stop pump. Depress valve handle fully and apply lubricant. Rotate handle to distribute lubricant. To resume normal filtering operation, rotate valve handle to **FILTER** position and start pump.

VACUUMING YOUR POOL

Prior to vacuuming, clean out strainer assembly basket on your Power Pak and backwash your Silica II™ Filter thoroughly. Follow skimmer manufacturer's instructions for vacuuming pool. It may be necessary to backwash

your filter frequently during the vacuuming operation. For excessive amounts of dirt on the pool floor, we recommend that you vacuum directly to waste. This is accomplished by installing your wasteline (See wasteline hookup) and placing the filter valve handle in the PUMP TO WASTE position. Then proceed vacuuming as usual. When you've completed vacuuming, backwash your Silica II™ thoroughly and clean the strainer basket again. Resume normal filtering operation.

WINTERIZING (FREEZING CLIMATES)

With Doughboy Skimmer & Return Fitting

Drain pool water to 6" below return fitting. Rotate valve handle to PUMP TO WASTE position. (See Pump to Waste.) Turn pump on and run until water level is drawn down to skimmer level. Turn pump OFF. Additional water removal can be accomplished by syphoning with several garden hoses, or vacuum hoses. Rotate valve handle to the WINTERIZE position, and remove drain plug. (29). Your Silica II™ Filter must be drained, cleaned and stored indoors for the winter season. We strongly recommend, for the protection of your filter, liner and pool wall, that you purchase and install the DOUGHBOY Winterizing Kit (0-2099-001). The proper installation of this kit will allow the removal and storage of your skimmer and filter, and should eliminate any possibility of damage due to winter peril.

CAUTION

Removing the skimmer without installing a winterizing kit is very dangerous to the pool wall, liner and pool installation, and voids any warranty. Filter damage caused by freezing temperatures is not covered by product warranty.

To winterize Silica II™: Be sure pump is "OFF". Drain pool water level six inches below the return fitting by rotating valve handle on Silica II™ to the **WINTERIZE** position. Remove the Silica II™ drain plug (29). Disconnect all hoses after water is completely drained from tank. Remove tank flange bolts (16) and nuts (28). Lift cover off and set aside. Secure a clean plastic bag with a rubber band over pipe opening extending up from center of tank. Scoop sand out with a medium size can. Place sand in a plastic trash can and save for next season's use. If the sand is badly contaminated, discard it and purchase new sand next season. Store your pump and Silica II™ indoors for the winter season. Filter or pump damage caused by freezing temperatures is not covered by product warranty. For springstart-up, follow Filling Tank, Hose Installation and Initial Start-Up instructions in this guide.

PARTS LIST SILICA II™ - MODEL 0-1750-000

ITEM	P/N	QTY	DESCRIPTION	ITEM	P/N	QTY	DESCRIPTION
1	365-1920	1	Owners Guide	*21	1116-1184	1	Tank Cover Assembly
2	—	1	Warranty Card	22	308-1114	1	O-Ring, Tank
3	376-1050	1	Pin, Valve Handle	23	340-1190	1	Upper Distributor
4	327-1007	2	Friction Washer - Delrin	24	330-1024	4	#12 x 3/4" Screw
5	330-1025	6	#12 x 1 1/8" Screw	25	1116-1190	1	Periphery Underdrain Assy.
6	1121-1521	1	Valve Cover Assembly	26	330-1023	6	#8 x 5/8" Screw
7	395-1014	1	Pressure Gauge	27	340-1180	1	16" Dia. Molded Tank
8	308-1039	3	O-Ring, Hose Adaptor	28	321-1021	18	1/4" Flange Nut
9	340-1224	1	Hose Adaptor - Light Oak	29	340-1183	1	Plug, Tank Drain
10	327-1006	2	Valve Bearing Washer - S.S.	30	308-1043	1	O-Ring, Tank Drain
11	396-1023	1	Spring, Valve Rotor	31	340-1201	1	Sand Filter Drain
12	308-1044	1	O-Ring, Valve Rotor	32	346-1013-1	1	Hose, 1 1/2" x 2 1/2' Lg.
13	340-2229	1	Valve Rotor	33	346-1035-1	2	Hose, 1 1/2" x 8' Lg.
14	340-2228	1	Valve Handle	34	387-1017	6	Hose Clamp - 1 1/2"
15	307-1022	1	Gasket, Rotor Valve	35	343-1100	1	Air Relief
16	324-1020	18	1/4" Flange Bolt	36	326-1008	18	1/4" Washer
17	340-1299	1	Waste Port Adaptor	37	360-1467	1	Operating Instructions Label
18	307-1001	1	Gasket (Drain Cap)				
19	340-1035	1	Drain Cap				
20	340-1225	1	Hose Adaptor - Almond				

*NOTE: Tank Cover Assembly (item #21 above) includes items 15 and 37.

SILICA II • MODEL 0-1750-000

EXPLODED PARTS

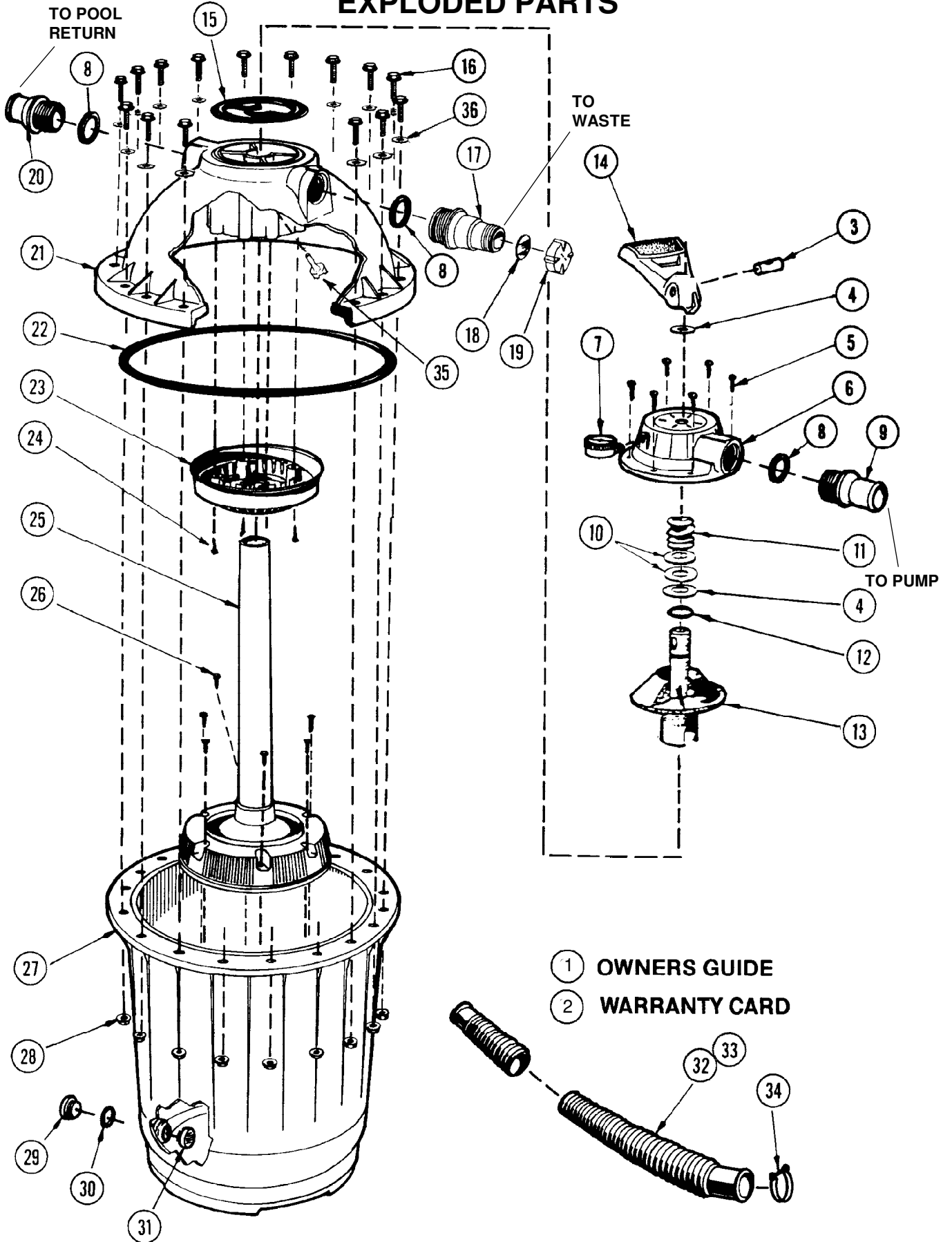

TROUBLE SHOOTING

A. High gauge pressure, low return flow.

1. Filter sand is too fine. (Use #20 crystal sand.)
2. Or, excessive contaminants or algae in sand.
3. Or, underdrain plugged due to fine sand. (Use #20 crystal sand.)
4. Or, insufficient backwashing. Backwash thoroughly.

B. Low gauge pressure, low flow. Pump suction is drawing in air (noted by bubbles returning to pool), or pump sounds like marbles are rattling in it.

1. Pool water level is too low. SWITCH PUMP "OFF" AT ONCE. Fill pool so water level is between markers on skimmer faceplate.
2. Or, there is a restriction on the suction side of the pump.
3. Or, pump strainer assembly is clogged with debris. Clean strainer assembly.

C. High flow, low or normal gauge pressure...but pool water won't clear up.

1. Pool water is chemically out of balance. Use water test kit to check balance.
2. Or, sand is too coarse. (Use #20 crystal sand.)
3. Or, rounded type sand used. (Use #20 crystal sand.)

D. Very short filtering cycles.

1. Backwash filter thoroughly.
2. Sand may be too fine. (Use #20 crystal sand.)
3. Or, excessive suspended contaminants or algae in sand.

4. Or, excessive suspended contaminants or algae in pool water. (Filter will require frequent backwashing until pool clears up.)

E. Cloudy puff coming out of return fitting.

1. Place valve handle in FILTER TO WASTE position when turning on pump and after backwashing.
2. Or, if vacuuming, place valve handle in PUMP TO WASTE position.

F. Water is leaking to waste.

1. Inspect drain cap (19) and gasket (18) for needed repair.
2. Actuate and rotate valve handle to clear seating area of debris.
3. Or, replace valve gasket in tank cover.

G. Filter is backwashing when valve handle is in FILTER position after servicing filter.

1. Valve cover is assembled backwards on tank cover (180° from correct position).

SERVICE

During disassembly of the filter, mark each part's assembled position as it relates to the mating part to assure proper alignment when reassembled. Malfunctioning of the filter will occur if not properly reassembled. Use only original Doughboy replacement parts. See your professional Doughboy pool dealer for Original Equipment Manufactured (OEM) parts and servicing.



Change of Design: Doughboy Recreational expressly reserves the right to change or modify the design and construction of any product in due course of our manufacturing procedures, without incurring any obligation or liability to furnish or install such changes or modifications on products previously or subsequently sold.



DOUGHBOY RECREATIONAL • 315 N. Sebastian St. • West Helena, AR 72390
Visit our website at www.doughboy-pools.com